

all stainless steel construction

MGS18 - DS 100-150

1.18



CE PED 97/23/CE
ATEX 94/9/CE

PG ME 48
Gost R Pattern Approval

PA Chinese Pattern Approval

These instruments are designed for food, processing, pharmaceutical, petrochemical industries and for conventional and nuclear power plants. They are built to resist to the most severe conditions created by the process medium and by the environment and for those fluids, which have high viscosity and do not crystallize. The quality of the materials used to build the sensible element allows their use with high frequency pulsating pressures.

The TIG welding between the case and the process socket, strengthens the instrument and assures a better tight in case of dampening fluid. The advantages of filling the case of the instrument with a dampening fluid are: reduced pointer fluctuation, reduced wear of rotating parts of the movement when pulsant vibrations and pulsations occur. Moreover condensation and corrosive atmospheres which could damage the internal parts are prevented.

Functional and constructive characteristics

1.18.1 Standard

Accuracy class: 1 as per EN 837-1.
Ambient temperature -25...+65 °C.
Process fluid temperature: -40...+150 °C.
Working pressure (referred to the full scale value): max 90% for pulsating pressure; 100% for static pressure.
Over pressure limit: 30% of full scale value.
Special over pressure : 50% of full scale value, for pressure ranges ≤ 400 bar (max 1 hour) as option.
Protection: IP 55 as per IEC 529.
Socket material: AISI 316L st.st.
Elastic element: AISI 316L st. st. seamless tube.
Case: AISI 304 st.st.
Ring: AISI 304 st.st. , bayonet lock.
Window: tempered glass.
Movement: stainless steel with internal limit stops for minimum and maximum pressure.
Dial: aluminium, white with black markings and "▼" symbol at the edges of the scale value.
Special dial: ranges different from standard, custom artworks available on request.
Pointer: aluminium, micrometric adjustable, black painted.
Gasket, blow out vent and filling plug: EPDM

1.18.2 Fillable

Protection: IP 67 as per IEC 529.
Pointer: aluminium, non-adjustable, black painted.
Note: suitable for glycerine filling, silicone oil filling available on request (code P01).
Other features: as type 1.18.1 (as type 1.18.3, when filled).

1.18.3 Liquid filled

Ambient temperature: max +65 °C, (see DAMPING LIQUIDS table on page 4 for further information)
Process fluid temperature: max +65 °C.
Protection: IP 67 as per IEC 529.
Damping liquids: glycerine 98%, silicone oil on request (code S10).
Pointer: aluminium, non-adjustable, black painted.
Other features: as type 1.18.1 Standard



For use in potentially explosive atmospheres, instruments must be designed in conformity to ATEX 94/9/CE. This version is identified by code 2G1 and 2D1 and is shown on separate data sheet available on request.

TYPE, DIMENSIONS AND WEIGHTS

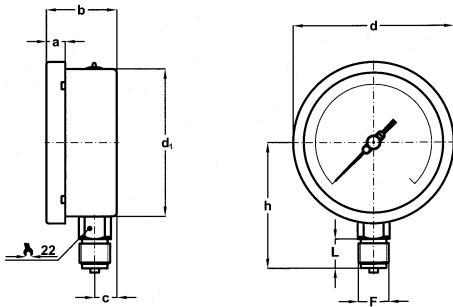

TYPE A
stem mounting;
lower connection.

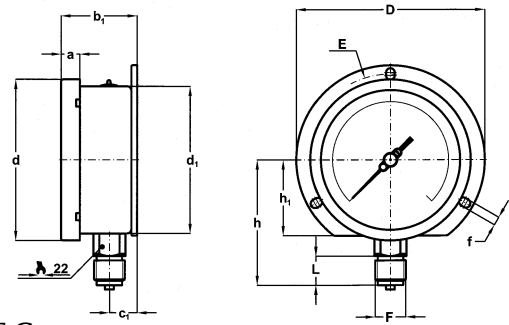

TYPE C
surface mounting, back flange;
lower connection.

DS	Type	a	b	b ₁	c	c ₁	d	d ₁	f	h ₁	D	E	ch	Weight 1.18.1-2	Weight 1.18.3
100	A-C	13	48,5	52,5	15	19	110,6	101	6	52	130	116...120	22	0,53 Kg.	0,86 Kg.
150	A-C	15	50,5	54	15,5	19	161	149,6	6	85	190	168...178	22	1,02 Kg.	1,80 Kg.

(dimensions in mm.)

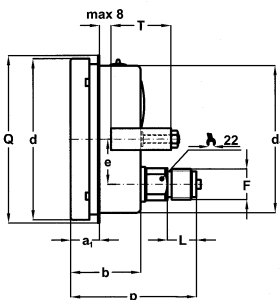

TYPE B
flush mounting, "U" -Clamp;
back connection.

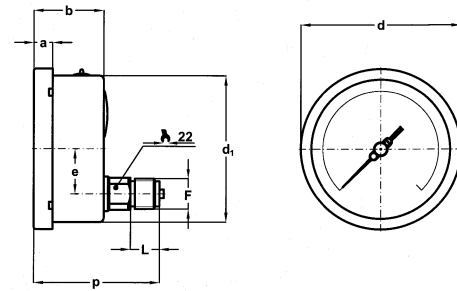

TYPE D
stem mounting;
back connection.

DS	Type	a	a ₁	a ₂	b	d	d ₁	e	f	h ₁	D	E	Q	T	V	Z	ch	Weight 1.18.1-2	Weight 1.18.3
100	B-D-E	13	20	20	48,5	110,6	101	31	6	/	132	116...120	112	41,5	70	112	22	0,52 kg	0,85 kg
150	B-D-E	15	20,5	25,5	50,5	161	149,6	48	6	85	190	168...178	164	41,5	106	155	22	0,95 kg	1,73 kg

(dimensions in mm.)

PROCESS CONNECTIONS

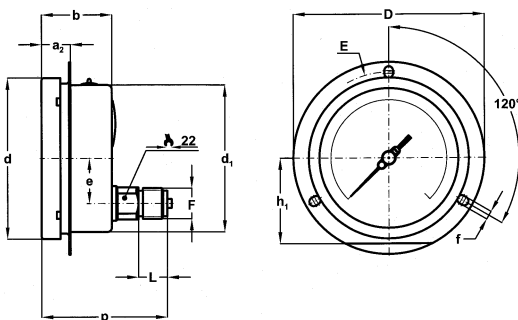

TYPE E
flush mounting, front flange;
back connection.

F	Code	DS 100			DS 150		
		L	h	p	L	h	p
G 1/4 A	21M	13	79	85	13	110	83,5
1/4-18 NPT	23M	15	81	87	15	112	85,5
G 3/8 A	31M	16	86	87	16	113	85,5
3/8-18 NPT	33M	16	86	87	16	113	85,5
G 1/2 A	41M	20	86	87	20	117	85,5
R 1/2-ISO 7/1	42M	20	86	87	20	117	85,5
1/2-14 NPT	43M	20	86	87	20	117	85,5
M 20 x 1,5	97M	20	86	87	20	117	85,5

(dimensions in mm.)

RANGES - "E" = DS 100; "G" = DS 150.

PRESSURE

TAB. 1

RANGE	bar	kPa	MPa	bar ext.	bar ext.	bar ext.
				psi int.	kPa int.	MPa int.
0...0,6 (1)	E G			E G	E G	
0...1	E G		E G	E G	E G	
0...1,6	E G		E G	E G	E G	
0...2,5	E G		E G	E G	E G	
0...4	E G		E G	E G	E G	
0...6	E G		E G	E G	E G	
0...10	E G		E G	E G		E G
0...16	E G		E G	E G		E G
0...25	E G		E G	E G		E G
0...40	E G		E G	E G		E G
0...60	E G	E G (1)	E G	E G		E G
0...100	E G	E G	E G	E G		E G
0...160	E G	E G	E G	E G		E G
0...250	E G	E G		E G		E G
0...300	E G					
0...400	E G	E G		E G		E G
0...600	E G	E G		E G		E G
0...1000	E G	E G		E G		E G
0...1600	E G	E G		E G		E G
0...2500		E G				

(1) not available for MGS 18/3 (1.18.3)

TAB. 2

RANGE	psi	psi int.	psi ext.	psi ext.
		kPa est.	bar int.	Kg/cm ² int.
0...15	E G	E G	E G	E G
0...30	E G	E G	E G	E G
0...60	E G	E G	E G	E G
0...100	E G	E G	E G	E G
0...160	E G	E G	E G	E G
0...200	E G	E G	E G	E G
0...300	E G	E G	E G	E G
0...400	E G	E G	E G	E G
0...600	E G	E G	E G	E G
0...1000	E G	E G	E G	E G
0...1500	E G	E G	E G	E G
0...2000	E G	E G	E G	E G
0...3000	E G	E G	E G	E G
0...4000	E G	E G	E G	E G
0...5000	E G	E G	E G	E G
0...6000	E G	E G	E G	E G
0...10000	E G	E G	E G	E G
0...15000	E G	E G	E G	E G
0...20000	E G	E G	E G	E G
0...30000 (1)	E G	E	E	E

(1) working pressure: max 75% of the full scale value
over pressure limit: 10% of the full scale value

VACUUM & COMPOUND

TAB. 4

RANGE	bar	kPa	bar ext.	bar ext.
			psi int.*	kPa int.
-1...0	E G		E G	E G
-1...0,6	E G		E G	E G
-1...1,5	E G		E G	E G
-1...3	E G		E G	E G
-1...5	E G		E G	E G
-1...9	E G		E G	E G
-1...15	E G		E G	E G
-1...24	E G		E G	E G
-100...0		E G		
-100...150		E G		
-100...300		E G		
-100...500		E G		
-100...900		E G		
-100...1500		E G		
-100...2400		E G		

* vacuum unit of measurement: "inHg"

TAB. 3 - Receiver

External	Internal	Internal
	0÷100 linear	0÷10 quadratic
0,2...1 bar	E G	E G
0,2...1 kg/cm ²	E G	E G
3...15 psi	E G	E G
20...100 kPa	E G	E G

TAB. 5

RANGE	psi*	psi int.*	psi ext.*	psi ext.*
		kPa ext.	bar int.	kg/cm ² int.
-30...0	E G	E G	E G	E G
-30...15	E G	E G	E G	E G
-30...30	E G	E G	E G	E G
-30...150	E G	/	E G	/

* vacuum unit of measurement: "inHg"

TAB. 6 - NH₃

bar external	NH ₃ internal	
-1...5	-70...+9°C	E
-1...9	-70...+25°C	E
-1...15	-70...+40°C	E
-1...24	-70...+56°C	E

INSTRUMENTS FOR OXYGEN

To suit safety criteria of standard EN837.1-2, the pressure gauges for oxygen service must be solid-front type (with baffle wall and safety bursting back).

Pressure gauges suitable for this service are detailed on 1.20 DS 100-150 sheet.

OPTIONS - "E" = DS 100; "G" = DS 150.

DESCRIPTION	CODE	1.18.1 (standard)	1.18.2 (fillable)	1.18.3 (filled)
ATEX version II 2G c	2G1	<i>Constructive characteristics and ordering guide please refer to the relevant ATEX version data sheet.</i>		
ATEX version II 2GD c	2D1			
AISI 316 st.st. case and ring	C40	E G	E G	E G
Accuracy class: 0,6 as per EN 837-1 (1)	K06	E G	E G (2)	
Non-adjustable pointer	L01	E G	STD	STD
Adjustable pointer	L02	STD	E G	E G
Maximum pointer IP 44 on plexiglas window (6)	L21	E G		
Maximum pointer IP 65 on plexiglas window (6)	L22	E G	E G	E G
AISI 304 st.st. movement, with brass gearing (3)	M01	E	E	E
Suitable for filling with silicone (4)	P01		E G	
Without restrictor	S03	E G (7)	E G	E G
Silicone filling (4)	S10			E G
Overpressure 50% of the full scale value for ranges \leq 400 bar	SVP	E G	E G	E G
Tropicalisation	T01	E G	E G	E G
Stainless steel label	T25	E G	E G	E G
Plexiglas window	T31	E G	E G	E G
Safety glass window	T32	E G	E G	E G
Restrictor 0,7 mm	V11	E G (5)	STD	STD

- (1) for ranges up to 400 bar/6000 PSI, not available for receivers
 (2) to be ordered with option L02
 (3) accuracy class: 1 as per EN 937-1, without internal stops
 (4) window gasket: silicone rubber; blow out vent & filling plug: VITON
 (5) std for pressure ranges \geq 60 bar
 (6) accuracy class is guaranteed when the indicating pointer is not affected by the maximum pointer
 (7) std for pressure ranges < 60 bar

HOW TO ORDER

During 2004 ordering guide could be modified. We regret for any inconvenience that could arise in ordering this product.

1	1 - bourdon tube pressure gauges
18	18 - all st. st. construction MGS18
2	1 - standard version 2 - fillable version 3 - liquid filled
C	A - lower connection - stem mounting B - back connection - flush mounting, "U"-clamp C - lower connection - surface mounting, back flange D - back connection - stem mounting E - back connection - flush mounting, front flange
E	E - DS 100 G - DS 150
0/10 bar	see ranges table
41M	see process connection table
M01	see options table

DAMPING LIQUIDS

Damping liquids	Ambient temperature
Glycerine 98%	+15...+65 °C (+60...+150 °F)
Silicone oil	-45...+65 °C (-50...+150 °F)

ACCESSORIES

Diaphragm seals: a complete range of diaphragm seals are available with a choice of materials of construction. Specifically for corrosive and difficult process fluids plus hygienic applications. For further details refer to relevant data sheets.

Adjustable over-load protector: this is useful for installations which may generate high overpressures; the pressure gauges is automatically excluded at the pre-set pressure and cut in again automatically when the operating pressure returns to normal. For further details refer to relevant data sheet.

Valves: for construction details and for use limits refer to relevant data sheet.

Pigtail and siphons: recommended with temperatures of 65° C (150° F) or over. For further details refer to relevant data sheet.

Pressure snubbers: for further details refer to relevant data sheet.